

Discrete Time Systems Described By Difference Equations:

To Compute The Cumulative Average:

$$y(n) = \frac{1}{n+1} \sum_{k=0}^n x(k) \quad n = 0, 1, \dots$$

We can simplify:

$$(n+1)y(n) = \sum_{k=0}^{n-1} x(k) + x(n)$$

$$= ny(n-1) + x(n)$$

$$y(n) = \frac{n}{n+1}y(n-1) + \frac{1}{n+1}x(n)$$

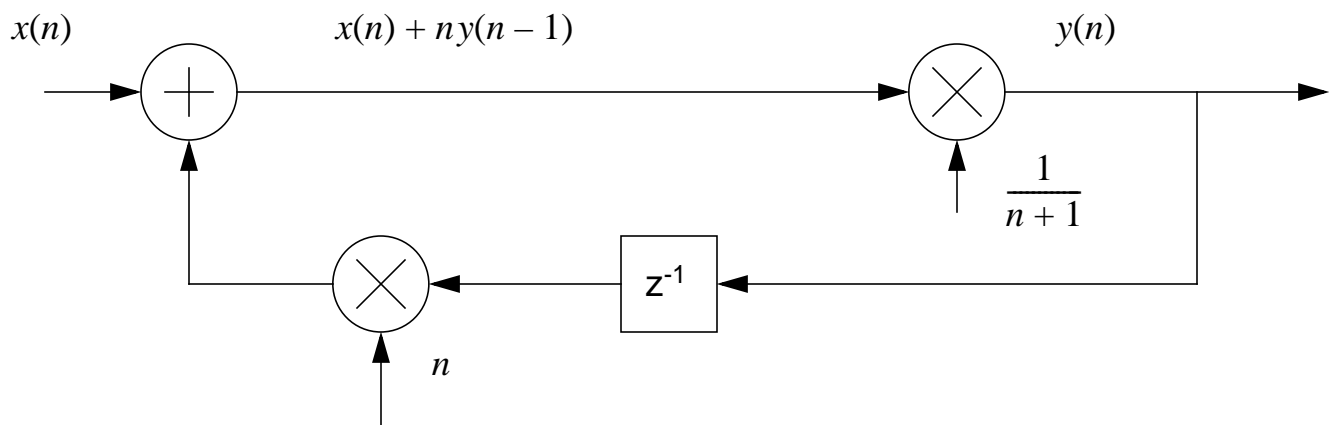

Linear Time-Invariant Systems Characterized by Constant-Coefficient Difference Equations:

$$y(n) = - \sum_{k=1}^N a_k y(n-k) + \sum_{k=0}^M b_k x(n-k)$$

N is the order of the system (analogous to D.E. orders)

First summation is called “autoregressive” component

Second summation is called the “moving average” component

Is this system linear if the coefficients are time-varying?

Solutions of Linear Constant-Coefficient Difference Equations:

$$y(n) = y_h(n) + y_p(n)$$

$y_h(n)$ is the homogeneous or complementary solution

$y_p(n)$ is the particular solution

The general form of the homogenous solution is:

$$y_h(n) = C_1\lambda_1^n + C_2\lambda_2^n + C_3\lambda_3^n + \dots$$

For a linear system, assume only one form of λ .

To find $y_h(n)$, set $y_p(n) = 0$:

$$\sum_{k=0}^N a_k \lambda^{n-k} = 0$$

or,

$$\lambda^{n-N} (\lambda^N + a_1 \lambda^{N-1} + a_2 \lambda^{N-2} + \dots + a_{N-1} \lambda + a_N) = 0$$

This is called the characteristic equation (important tool).

The coefficients of the general solution are determined from the initial conditions (see Example 2.4.4)

The particular solution is found in an analogous manner.

The total solution is the sum of both.

Most of the time, we assume the initial conditions are zero.

Why is the characteristic equation important?

It can be shown that:

If,

$$\sum_{n=0}^{\infty} |\lambda_k|^n < \infty$$

then,

$$\sum_{n=0}^{\infty} |h(n)| < \infty$$

necessary and sufficient stability condition:

$$|\lambda_k| < 1$$

Implementation of Discrete-Time Systems:

(1) Direct Form I

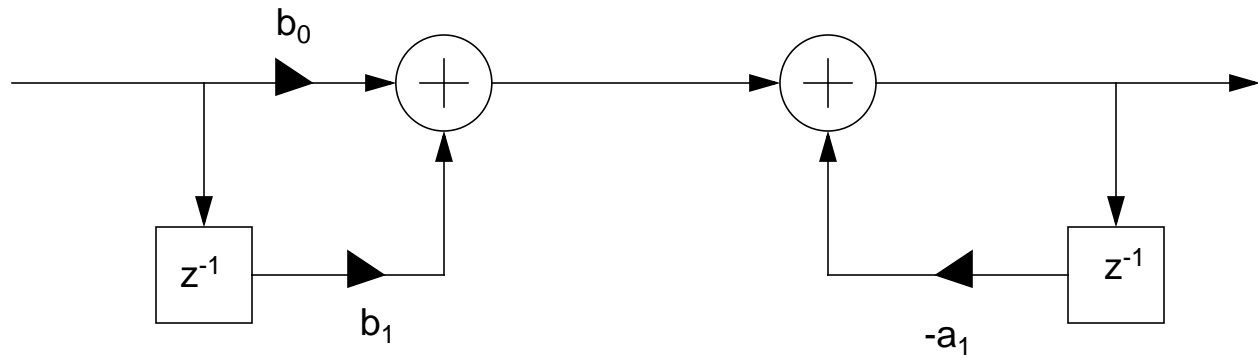

(2) Direct Form II

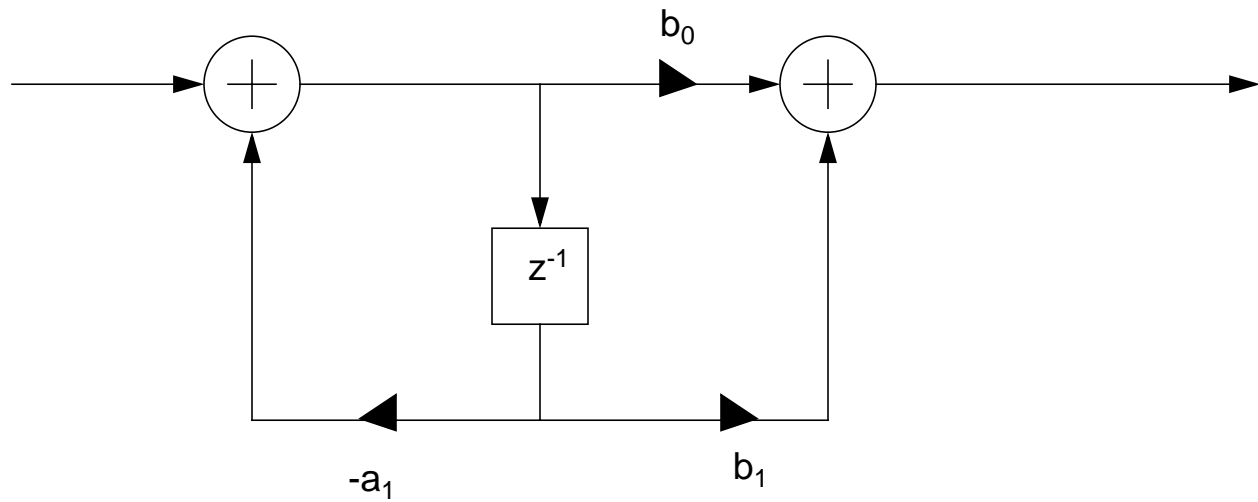

A realization of a finite impulse response (FIR) filter:

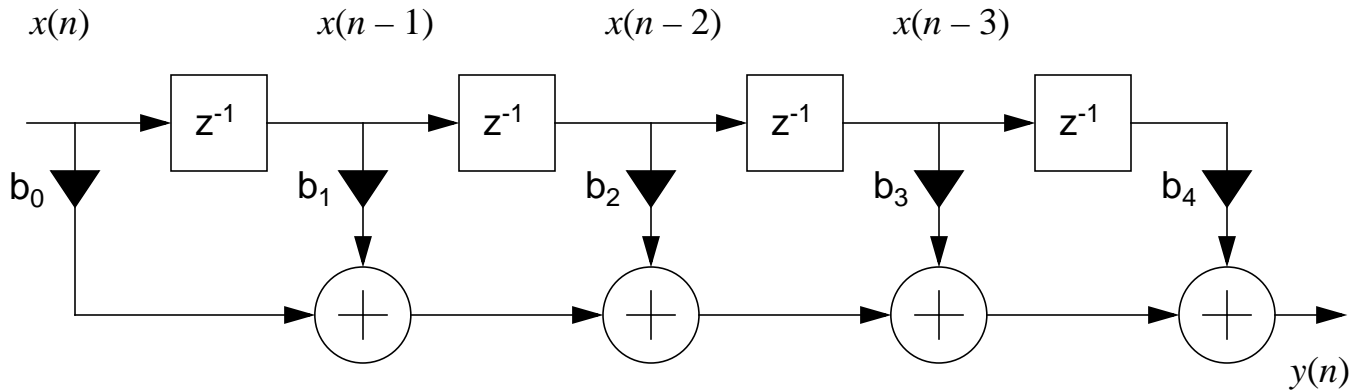

A realization of an infinite impulse response filter (purely recursive):

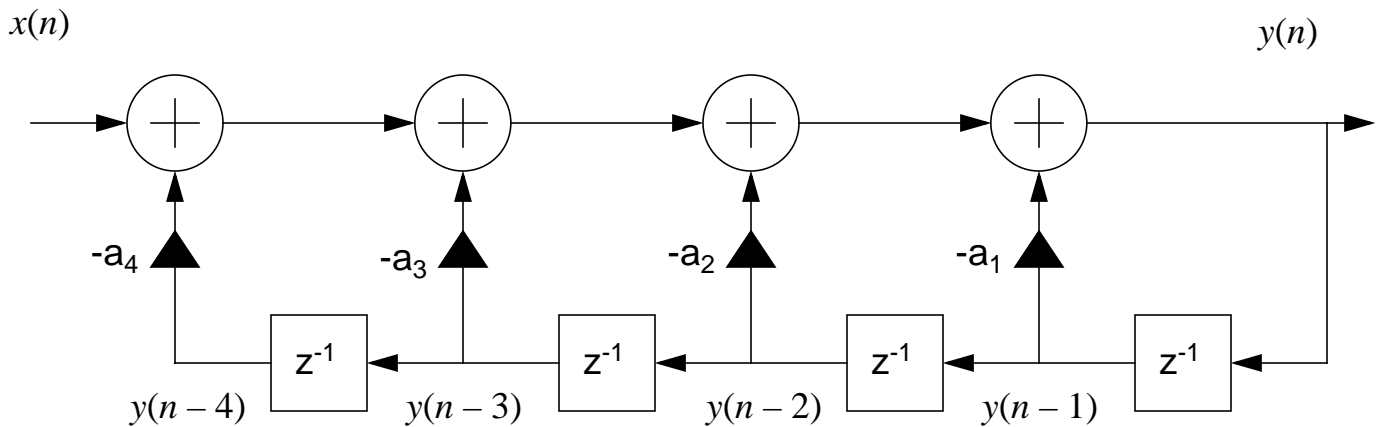

Inversion (Analysis/Synthesis)???

How do we code this?

