

Name:

Problem	Points	Score
1a	10	
1b	10	
1c	10	
1d	10	
2a	10	
2b	10	
3a	10	
3b	10	
3c	10	
3d	10	
Total	100	

Notes:

1. The exam is open books/open notes.
2. Please show ALL work. Incorrect answers with no supporting explanations or work will be given no partial credit.
3. Please indicate clearly your answer to the problem.

Problem No. 1: Z-Transforms

(a) Determine the impulse response, $h(n)$, for the causal system whose z -transform is:

$$H(z) = \frac{-3}{(1.5z - 3)(9 - 4.5z^{-1})}$$

$$H(z) = \left(\frac{-3}{9}\right) \left(\frac{z}{z^{-1}}\right) \frac{1}{(-3)\left(1 - \frac{1}{2}z\right)\left(1 - \frac{1}{2}z^{-1}\right)}$$

$$= \left(\frac{1}{9}\right) \frac{z^{-1}}{\left(-\frac{1}{2} + z^{-1}\right)\left(1 - \frac{1}{2}z^{-1}\right)}$$

$$= \frac{-2}{9} \frac{z^{-1}}{\left(1 - 2z^{-1}\right)\left(1 - \frac{1}{2}z^{-1}\right)} = \left(\frac{-2}{9}\right) \left(\frac{A}{\left(1 - 2z^{-1}\right)} + \frac{B}{\left(1 - \frac{1}{2}z^{-1}\right)} \right)$$

Using partial fractions expansion,

$$A\left(1 - \frac{1}{2}z^{-1}\right) + B\left(1 - 2z^{-1}\right) = z^{-1}$$

$$A + B = 0 \quad -\frac{1}{2}A - 2B = 1$$

$$A = -B \quad -\frac{1}{2}A + 2A = 1 \quad A = \frac{2}{3} \quad B = -\frac{2}{3}$$

Therefore,

$$H(z) = \left(-\frac{4}{27}\right) \left(\frac{1}{1 - 2z^{-1}} - \frac{1}{1 - \frac{1}{2}z^{-1}} \right)$$

$$h(n) = \left(\frac{-4}{27}\right) \left(2^n - \left(\frac{1}{2}\right)^n\right) u(n)$$

(b) Is this filter stable? Explain.

No. One pole is outside the unit circle ($z = 2$).

(c) Draw a parallel realization of the filter.

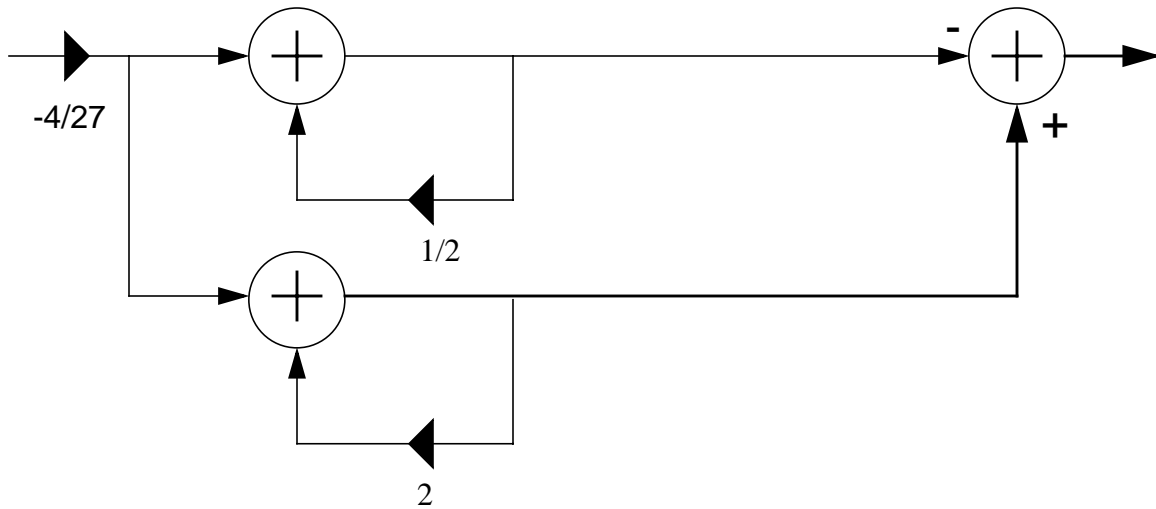

(d) Describe to me the approximate response of this system to the signal:

$$x(n) = \left(27 \sin\left(2\pi \frac{2000}{f_s} n + \frac{\pi}{2}\right) + (10^{-3})^n \right) u(n) \quad \text{for } 10^9 < n < 10^{11}$$

for $f_s = 8000 \text{ Hz}$.

Since the system is unstable, the envelope of the output grows exponentially.

Problem No. 2: Filter Design

- (a) Compute the impulse response of the filter shown to the right.

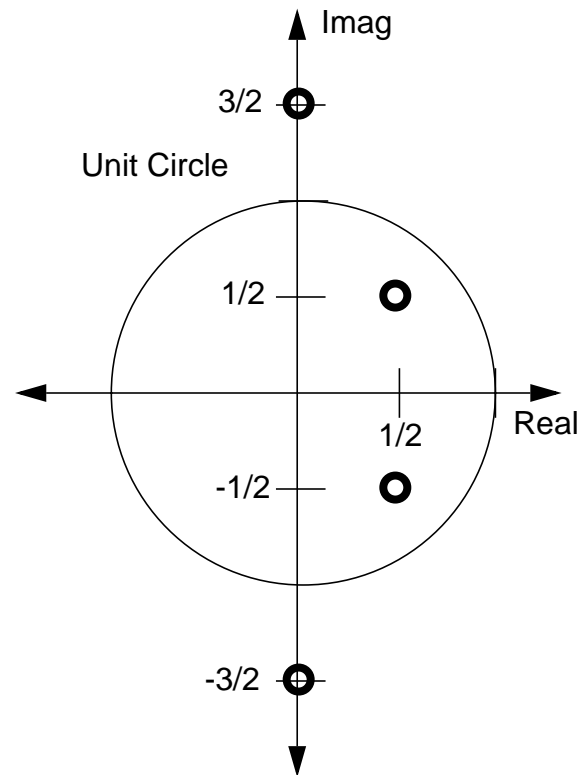

$$\begin{aligned}
 H(z) &= (1 - 2\operatorname{Re}\{a\}z^{-1} + |a|^2z^{-2})(1 - 2\operatorname{Re}\{b\}z^{-1} + |b|^2z^{-2}) \\
 &= \left(1 - z^{-1} + \frac{1}{2}z^{-2}\right)\left(1 + \frac{9}{4}z^{-2}\right) \\
 &= 1 - z^{-1} + \frac{1}{2}z^{-2} + \frac{9}{4}z^{-2} - \frac{9}{4}z^{-3} + \frac{9}{8}z^{-4} \\
 &= 1 - z^{-1} + \frac{11}{4}z^{-2} - \frac{9}{4}z^{-3} + \frac{9}{8}z^{-4}
 \end{aligned}$$

Therefore,

$$h(n) = A \left\{ 1, -1, \frac{11}{4}, -\frac{9}{4}, \frac{9}{8} \right\}$$

- (b) Is this filter stable? Yes.

Is this filter minimum phase? No.

Problem No. 3: Deconvolution and System Identification

- (a) The evil Dr. Anne A. Log has finally captured her longtime nemesis, Dr. DeEspy. Before she is about to drain Dr. DeEspy's brain with her famous brain-drain machine (she watched the original Star Trek series as a child), she felt a twinge of guilt and decided to leave one mathematical equation left in Dr. DeEspy's brain. Dr. A.A. Log, a former graduate of EE 4773, remembered that her instructor had told her, in such a situation, there was one and only one equation that Dr. DeEspy would want to remember. What is this most important equation?

The quadratic equation.

- (b) As Dr. Log proceeds to turn on the switch, halfway around the world, the Mighty Power Transformers, including Zee, who is known for transforming himself into circular shapes, was watching. Zee was sure this was no longer a con game, and realized the situation was very unstable. Hence, he prepared to transmit a signal to destroy the brain-drain machine. The only problem was that Zee hadn't taken EE 4773.

Zee knew that distortion of the signal to be sent was a serious problem. He measured the channel characteristic as:

$$H(z) = \frac{4}{4 + 4z^{-1} + 2z^{-2}}$$

Is this channel model stable?

Yes. The poles are at $z = \frac{-4 \pm \sqrt{16 - 32}}{8} = -\frac{1}{2} \pm \frac{1}{2}j$, and $|z_k| < 1$.

- (c) To destroy the brain drain machine, a large impulse ($\delta(n)$) must be injected into the machine at the location of the machine. What time-domain signal should Zee transmit from his lab (located at halfway around the world at the sending end of the channel model), such that when it is passed through the channel, it arrives at brain-drain machine in Dr. Log's lab as an impulse function?

$$H_I = 1 + z^{-1} + \frac{1}{2}z^{-2}$$

$$h(n) = \delta(n) + \delta(n-1) + \frac{1}{2}\delta(n-2)$$

- (d) Zee, who is often wrong on such matters, decides the answer to part (c) is:

$$x(n) = 6\delta(n) + (3 + 3j)\delta(n-1)$$

Compute the output of the system to this input.

$$X(z) = 6 + (3 + 3j)z^{-1}$$

$$Y(z) = H(z)X(z)$$

$$= (6 + (3 + 3j)z^{-1}) \frac{1}{\left(1 - \left(-\frac{1}{2} + \frac{1}{2}j\right)z^{-1}\right)\left(1 - \left(-\frac{1}{2} - \frac{1}{2}j\right)z^{-1}\right)}$$

$$= 6 \frac{1}{\left(1 - \left(-\frac{1}{2} + \frac{1}{2}j\right)z^{-1}\right)}$$

$$y(n) = 6\left(-\frac{1}{2} + \frac{1}{2}j\right)^n u(n)$$