

Name: Tim Schlichter

Problem	Points	Score
1a	10	
1b	10	
1c	10	
1d	10	
2a	10	
2b	10	
2c	10	
3a	10	
3b	10	
3c	10	
Total	100	

Notes:

1. The exam is closed books/closed notes - except for one page of notes.
2. Please show ALL work. Incorrect answers with no supporting explanations or work will be given no partial credit.
3. Please indicate clearly your answer to the problem. If I can't read it (and I am the judge of legibility), it is wrong. If I can't follow your solution (and I get lost easily), it is wrong. All things being equal, neat and legible work will get the higher grade 😊

Problem No. 1: Block Diagrams

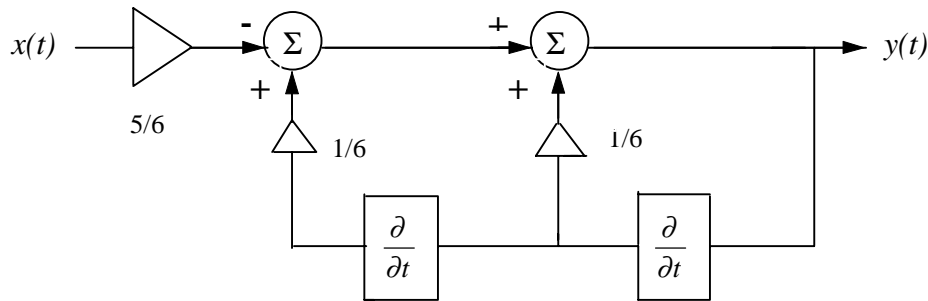

(a) Find the transfer function of this system using Laplace transforms.

First, the block diagram must be changed from the time domain to the Laplace domain. This changes the inputs $x(t)$ and $y(t)$ to $X(s)$ and $Y(s)$. Due to the differentiation theorem, the blocks labeled $\frac{\partial}{\partial t}$ are changed to $[s]$ in the Laplace domain. See the definition of the differentiation theorem shown in Problem 2. The transfer function is given by $Y(s)/X(s)$. Let $Z(s)$ be the result after the first summation:

$$Z(s) = \frac{1}{6}s^2Y(s) - \frac{5}{6}X(s)$$

$$Y(s) = Z(s) + \frac{1}{6}sY(s)$$

Substituting the first equation into the second yields the expression for $Y(s)$:

$$Y(s) = \frac{1}{6}s^2Y(s) - \frac{5}{6}X(s) + \frac{1}{6}sY(s)$$

$$Y(s) \left[\frac{1}{6}s^2 + \frac{1}{6}s - 1 \right] = \frac{5}{6}X(s)$$

$$\frac{Y(s)}{X(s)} = H(s) = \frac{1}{s^2 + s - 6} = \frac{1}{(s+3)(s-2)}$$

(b) Find the impulse response.

The impulse response of the system, $h(t)$, is found by taking the Inverse Laplace Transform of the transfer function $H(s)$. This involves using partial fractions to separate the terms in the denominator of $H(s)$:

$$H(s) = \frac{A}{s+3} + \frac{B}{s-2}$$

$$A = (s+3)H(s)|_{s=-3} = -\frac{1}{5}$$

$$B = (s-2)H(s)|_{s=2} = \frac{1}{5}$$

$$h(t) = L^{-1}\{H(s)\} = -\frac{1}{5}L^{-1}\left\{\frac{1}{s+3}\right\} + \frac{1}{5}L^{-1}\left\{\frac{1}{s-2}\right\}$$

$$h(t) = \left(-\frac{1}{5}e^{-3t} + \frac{1}{5}e^{2t}\right)u(t)$$

(c) Determine whether the system is stable or unstable. Show ALL work – the correct answer with no supporting work gets no points. Be as detailed as possible.

There are three techniques for determining the stability of a system:

1. $\int_{-\infty}^{\infty} |h(t)| dt < \infty$
2. If any roots of the denominator of $H(s)$ are on the right-hand side of the complex plane, the system is unstable.
3. If the number of sign changes in the first column of the Routh Array is equal to zero, the system is stable. The number of sign changes is equal to the number of right hand side poles.

Using the first method,

$$\begin{aligned} \int_{-\infty}^{\infty} |h(t)| dt &= -\frac{1}{5} \int_{-\infty}^{\infty} (|e^{-3t}| dt) u(t) + \frac{1}{5} \int_{-\infty}^{\infty} (|e^{2t}| dt) u(t) \\ &= -\frac{1}{5} \int_0^{\infty} e^{-3t} dt + \frac{1}{5} \int_0^{\infty} e^{2t} dt \\ &= \frac{1}{15} e^{-\infty} - \frac{1}{15} + \frac{1}{10} e^{\infty} - \frac{1}{10} \end{aligned}$$

The third term goes to infinity, so the first method shows that the system is unstable.

The second method is the simplest way to determine the stability of the system. The poles of this system are located at $s = -3$ and $s = 2$. The second pole is clearly in the right hand side of the complex plane, so this shows that the system is unstable.

The Routh Array is defined by the following matrix:

s	coefficients		
s^n	a_n	a_{n-2}	a_{n-4}
s^{n-1}	a_{n-1}	a_{n-3}	a_{n-5}
s^{n-2}	b_1	b_2	b_3
s^{n-3}	c_1	c_2	c_3

where:

$$b_1 = \frac{a_{n-1}a_{n-2} - a_n a_{n-3}}{a_{n-1}}$$

and so forth.

$$b_2 = \frac{a_{n-1}a_{n-4} - a_n a_{n-5}}{a_{n-1}}$$

The Routh Array for this problem is given as follows:

s	Coefficients	
s^2	1	-6
s^1	1	0
s^0	-6	

Since there is one sign change, there is one right-hand side pole, and the system is unstable.

(d) Sketch the frequency response (magnitude only) of the system using Bode plots.

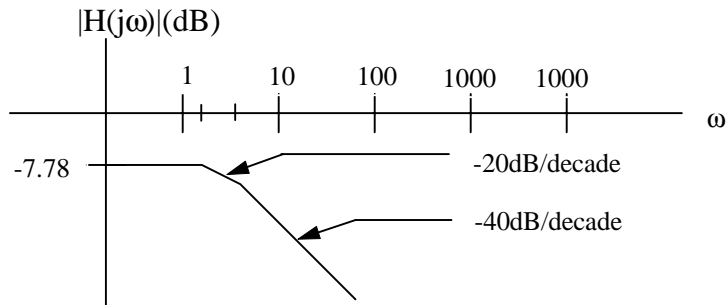

Problem No. 2: Circuit analysis using Fourier transforms.

For the circuit shown below:

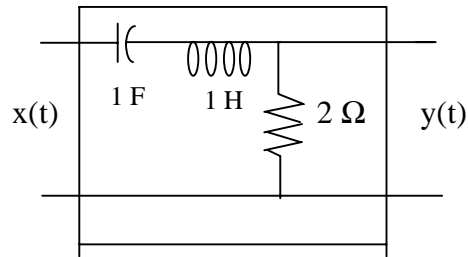

(a) State all the Fourier transform theorems that are invoked when you compute the transfer function of this circuit. You must give specific evidence to support each theorem described (and I must be able to understand your logic!).

1. **Linearity:** The transfer function is found by first converting the entire circuit to the frequency domain by taking the Fourier transform of each element in the circuit. By using the linearity theorem, the Fourier transform of the entire circuit is equivalent to the sum of the Fourier transforms of each element in the circuit:

$$\mathfrak{S}\{a_1 x_1(t) + a_2 x_2(t)\} = a_1 \mathfrak{S}\{x_1(t)\} + a_2 \mathfrak{S}\{x_2(t)\}$$

2. **Differentiation:** The circuit is a simple voltage divider network, so a loop equation can be written to find the transfer function. Thus, the voltage across the inductor must be found, which involves the differentiation theorem:

$$\mathfrak{S}\left\{\frac{d^n x(t)}{dt^n}\right\} = (j\omega)^n X(\omega)$$

$$v_L(t) = L \frac{di(t)}{dt}$$

$$\mathfrak{S}\{v_L(t)\} = \mathfrak{S}\left\{L \frac{di(t)}{dt}\right\} = L \mathfrak{S}\left\{\frac{di(t)}{dt}\right\}$$

$$V_L(\omega) = (j\omega L) I_L(\omega)$$

3. **Integration:** This theorem is used to convert the voltage across the capacitor to the frequency domain:

$$\mathfrak{S}\left\{\int_{-\infty}^t x(t') dt'\right\} = \frac{1}{j\omega} X(\omega) + X(0)\delta(\omega)$$

$$v_c(t) = \frac{1}{C} \int i_c(x) dx$$

$$\mathfrak{S}\{v_c(t)\} = \mathfrak{S}\left\{\frac{1}{C} \int i_c(x) dx\right\} = \frac{1}{C} \mathfrak{S}\left\{\int i_c(x) dx\right\}$$

$$V_c(\omega) = \frac{1}{j\omega C} I_c(\omega)$$

(b) State and prove the Frequency Translation Theorem.

The frequency translation theorem is as follows:

$$\mathfrak{S}\{x(t)e^{j\omega_0 t}\} = X(\omega - \omega_0)$$

To prove the theorem, consider $X(\omega)$:

$$X(\omega) = \mathfrak{S}\{x(t)\} = \int_{-\infty}^{\infty} x(t)e^{-j\omega t} dt$$

Now,

$$\mathfrak{S}\{x(t)e^{j\omega_0 t}\} = \int_{-\infty}^{\infty} x(t)e^{j\omega_0 t} e^{-j\omega t} dt = \int_{-\infty}^{\infty} x(t)e^{-j(\omega - \omega_0)t} dt = X(\omega - \omega_0)$$

(c) Find the impulse response of the circuit using Fourier Transforms.

The impulse response is given by finding the transfer function of the circuit and then finding the inverse Fourier transform of the transfer function:

$$H(j\omega) = \frac{Y(j\omega)}{X(j\omega)} = \frac{2}{\frac{1}{j\omega} + j\omega + 2} = \frac{2j\omega}{(j\omega)^2 + 2j\omega + 1}$$

$$H(j\omega) = \frac{2j\omega}{(j\omega + 1)^2} = \frac{A}{j\omega + 1} + \frac{B}{(j\omega + 1)^2} = \frac{A(j\omega + 1) + B}{(j\omega + 1)^2}$$

Equating like powers of $j\omega$ yields the solutions for the coefficients A and B:

$$(j\omega)^1: 2 = A$$

$$(j\omega)^0: 0 = A + B \Rightarrow B = -2$$

$$H(j\omega) = \frac{2}{j\omega + 1} + \frac{-2}{(j\omega + 1)^2}$$

$$h(t) = \mathfrak{S}^{-1}\{H(j\omega)\} = 2\mathfrak{S}^{-1}\left\{\frac{1}{j\omega + 1}\right\} - 2\mathfrak{S}^{-1}\left\{\frac{1}{(j\omega + 1)^2}\right\}$$

$$h(t) = (2e^{-t} - 2te^{-t})u(t)$$

Problem No. 3: The Dreaded Thought Problem

Signal to Noise (SNR) ratio is defined as the ratio of the power of a signal and the power of the noise in a system, computed on a log scale and measured in dB:

$$SNR|_{dB} = 10 \log_{10} \left(\frac{P_{signal}}{P_{noise}} \right)$$

Assume the signal is given by $x(t) = \sin \omega_0 t$, and the noise is given by $w(t) = e^{-\alpha|t-n|}$, where $n \leq t \leq n+1$.

(a) Compute SNR in the time domain.

The power of a signal (in the time domain) is found by evaluating the following integral:

$$\begin{aligned} P &= \lim_{T \rightarrow \infty} \frac{1}{2T} \int_{-T}^T |x(t)|^2 dt \\ P_{sig} &= \lim_{T \rightarrow \infty} \frac{1}{2T} \int_{-T}^T \sin^2(\omega_0 t) dt \\ &= \lim_{T \rightarrow \infty} \frac{1}{2T} (2) \int_0^T \sin^2(\omega_0 t) dt = \lim_{T \rightarrow \infty} \frac{2}{2T} \int_0^T \left(\frac{1}{2} - \frac{1}{2} \cos(2\omega_0 t) \right) dt \\ &= \lim_{T \rightarrow \infty} \frac{2}{2T} \left[\left(\frac{T}{2} - \frac{1}{2} \cos(4\pi) \right) - \left(0 - \frac{1}{2} \cos(0) \right) \right] \\ &= \frac{1}{2} \end{aligned}$$

The noise is a decaying exponential function which repeats at each integer. For this reason, the power of the signal can be calculated by choosing $n=0$ and evaluating the integral over one period:

$$\begin{aligned} P_w &= \frac{1}{T} \int_0^T e^{-2\alpha t} dt \\ &= \frac{1}{T} \left(-\frac{1}{2\alpha} \right) e^{-2\alpha t} \Big|_0^T \\ T &= 1 \\ P_w &= \frac{1 - e^{-2\alpha}}{2\alpha} \end{aligned}$$

$$SNR = 10 \log_{10} \left(\frac{\frac{1}{2}}{\frac{1 - e^{-2\alpha}}{2\alpha}} \right) = 10 \log_{10} \left(\frac{\alpha}{1 - e^{-2\alpha}} \right)$$

(b) Compute SNR in the frequency domain and prove it is equivalent to the time domain calculation.

$$X(f) = \mathcal{F}^{-1}\{x(t)\} = \frac{1}{2j} \delta(f - f_0) - \frac{1}{2j} \delta(f + f_0)$$

Using Parseval's Theorem, the power calculated in the frequency domain is equal to the power calculated in the time domain. The power in the frequency domain is calculated as follows:

$$P = \sum_{-\infty}^{\infty} |X(f)|^2$$

$$P_{sig} = \int_{-\infty}^{\infty} \left[\left(\frac{1}{2} \right)^2 \delta^2(f - f_0) + \left(\frac{1}{2} \right)^2 \delta^2(f + f_0) \right] df$$

The preceding expression is a simplification after squaring the entire expression of the signal in the frequency domain. It is an expansion of the following form:

$$(a + b)^2 = a^2 + ab + b^2$$

The cross term (ab) is zero because this is two delta functions multiplied together. The delta functions have no common points (i.e. one is at f_0 and one is at $-f_0$), so together they cancel each other out.

Now, consider the definition of the delta function:

$$\delta(f) = \lim_{\Delta \rightarrow 0} \frac{1}{\Delta} \Pi\left(\frac{f}{\Delta}\right)$$

Since the magnitude of this pi function is one, squaring the function will not change the magnitude. This enables the evaluation of the integral to simplify to one:

$$P_{sig} = \frac{1}{4} + \frac{1}{4} = \frac{1}{2}$$

The power of the noise is found by obtaining the complex Fourier coefficient of the signal and using Parseval's Theorem (from above). The coefficient, W_n , is found as follows:

$$\begin{aligned}
W_n &= \int_0^1 w(t) e^{-j2\pi n t} dt = \int_0^1 e^{-(\alpha + j2\pi n)t} dt \\
&= -\frac{1}{(\alpha + j2\pi n)} e^{-(\alpha + j2\pi n)t} \Big|_0^1 \\
&= \frac{1 - e^{-(\alpha + j2\pi n)}}{\alpha + j2\pi n}
\end{aligned}$$

$$\begin{aligned}
P_w &= \sum_{-\infty}^{\infty} |W_n|^2 \\
&= \sum_{-\infty}^{\infty} \frac{e^{-2(\alpha + j2\pi n)} - 2e^{-(\alpha + j2\pi n)} + 1}{\alpha^2 + (2\pi n)^2}
\end{aligned}$$

Using a table containing infinite series, this expression reduces to the following:

$$P_w = \frac{1 - e^{-2\alpha}}{2\alpha}$$

So, the resulting SNR is equivalent to that calculated in the time domain:

$$SNR = 10 \log_{10} \left(\frac{\alpha}{1 - e^{-2\alpha}} \right)$$

(c) Explain how the SNR varies with ω_0 and α .

As α goes off to infinity, SNR will go to infinity.

The SNR has no variation with changes to ω_0 .