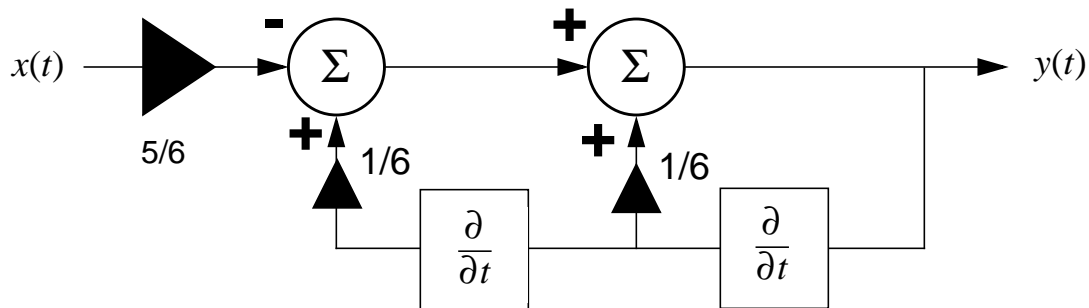

Name: Kevin Lewis

Problem	Points	Score
1a	10	
1b	10	
1c	10	
1d	10	
2a	10	
2b	10	
2c	10	
3a	10	
3b	10	
3c	10	
Total	100	

Notes:

1. The exam is closed books/closed notes - except for one page of notes.
2. Please show ALL work. Incorrect answers with no supporting explanations or work will be given no partial credit.
3. Please indicate clearly your answer to the problem. If I can't read it (and I am the judge of legibility), it is wrong. If I can't follow your solution (and I get lost easily), it is wrong. All things being equal, neat and legible work will get the higher grade:)

Problem No. 1: Block Diagrams

(a) Find the transfer function of this system using Laplace transforms.

The first thing that needs to be done is to transform the system into the frequency domain:

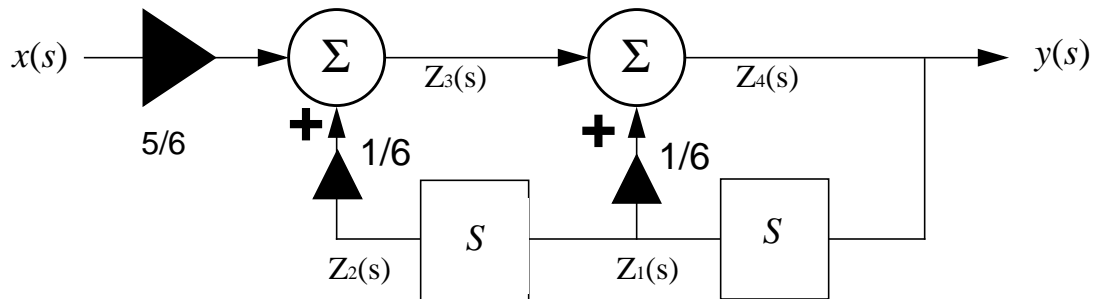

Then going through systematically the following equations are gotten:

$$Y(s) = Ay(s)$$

$$A_1(s) = Y(s)S$$

$$A_2(s) = S^2Y(s)$$

$$A_3(s) = -\frac{S}{6}X(s) + \frac{S^2}{6}Y(s)$$

$$A_4(s) = A_3(s) + \frac{(A_1(s))}{6} = -\frac{S}{6}X(s) + \frac{S^2}{6}Y(s) + \frac{S}{6}Y(s)$$

Combining the above equations, it is evident that Y(s) is a basic 2nd order differential equation

$$Y(s) = \frac{S^2}{6}Y(s) + \frac{S}{6}Y(s) - \frac{S}{6}X(s)$$

The above equation is modified so that Y(s) will be on one side of the equation :

$$1 = \frac{S^2}{6} + \frac{S}{6} - \frac{(5X(s))}{6Y(s)}$$

It is then modified so that $X(s)$ and $Y(s)$ are alone on the left side of the equation. This is done because $H(s)$...the transfer function...is equal to $Y(s)$ divided by $X(s)$.

$$\frac{5(X(s))}{6 Y(s)} = \frac{S^2}{6} + \frac{S}{6} - 1$$

The equation above has to be modified so that $H(s)$ can be gotten. To achieve this the reciprocal of the equation is taken, which gives the equation below:

$$\frac{5(Y(s))}{6 X(s)} = \frac{6}{S^2} + \frac{6}{S} - 1$$

$H(s)=Y(s)/X(s)$ so the equation has to be divided by $5/6$, which gives the equation shown below:

$$H(s) = \frac{(Y(s))}{X(s)} = \frac{5}{S^2 + S - 6}$$

(b) Find the impulse response.

The impulse response is the output in the time domain when a signal of infinitely short time is input to the circuit, so using the transfer function above, the system us transformed into the time domain using partial fractions to calculate pertinent data.

$$H(s) = \frac{5}{(S+3)(S-2)} = \frac{(AS+B)}{(S+3)(S-2)}$$

The solution to the partial fraction above is $A = -1$ and $B = 1$.

The transfer function is now in a form which is easily converted to the time domain:

$$H(s) = -\frac{1}{S+3} + \frac{1}{S-2}$$

Taking the Laplace transform:

$$L\{H(s)\} = H(t) = [(-e^{-3t}) + (e^{2t})]u(t)$$

(c) Determine whether the system is stable or unstable. Show ALL work. The correct answer with no supporting work gets no points. Be as detailed as possible.

Using the formula in the text (page 278), it is evident that the system is unstable because the poles are at +2 and -3. For the system to be stable, every pole in the system has to be negative. That is not the case here, so the system is unstable and the r.h.p. root is at 2.

(d) Sketch the frequency response (magnitude only) of the system using Bode plots.

The Bode plot is relatively easy to attain using basic networks skills. The transfer function is:

$$H(s) = \frac{5}{(s+3)(s-2)}$$

Because the system is unstable the Bode plot does not exist.

Problem No. 2: Circuit analysis using Fourier transforms.

For the circuit shown below:

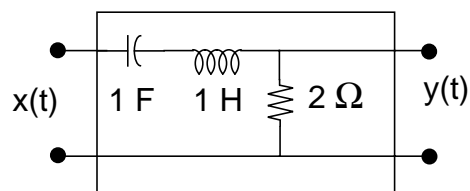

(a) State all the Fourier transform theorems that are invoked when you compute the transfer function of this circuit. You must give specific evidence to support each theorem described (and I must be able to understand your logic!).

The system is first transformed into the frequency domain:

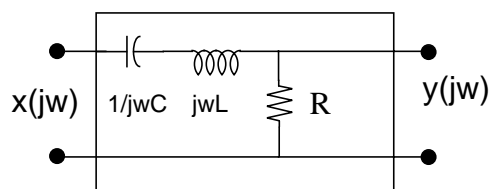

Superposition: Used when adding Inductance and Capacitance.

$$\frac{1}{j\omega C} + \frac{(1 - LC\omega^2)}{j\omega C}$$

DEPARTMENT OF ELECTRICAL AND COMPUTER ENGINEERING

The proofs of these equations can be found in the text.

Differentiation: Used when computing the current flowing through the inductor

$$\frac{\partial}{\partial t} i(t) = j\omega I(j\omega)$$

Integration: Used when computing the voltage across the capacitor

$$\left(-\frac{1}{C}\right) \int_{-\infty}^t i(t) dt = I \frac{(j\omega)}{j(\omega)} + \frac{1}{2} x(0) \zeta(j\omega)$$

(b) State and prove the Frequency Translation Theorem.

According to the text, the frequency translation theorem is:

$$\mathfrak{F}\{x(t)e^{j\omega_0 t}\} = X(\omega - \omega_0)$$

The following shows that the signal stays the same even when the frequency is shifted, and is analogous to the time delay theorem, which is proven in the text:

$$\int_{-\infty}^{\infty} [x(t)e^{j\omega_0 t}] e^{-j\omega t} dt = X(\omega - \omega_0)$$

$$\int_{-\infty}^{\infty} x(t) e^{-j(\omega - \omega_0)t} dt = X(\omega - \omega_0)$$

The right hand side is the Fourier transform of $x(t)$ with ω replaced by $(\omega - \omega_0)$

(c) Find the impulse response of the circuit using Fourier Transforms.

First the transfer function is gotten from the circuit diagram by inspection, then the entire equation is multiplied by $j\omega C$ to get it into the correct form:

$$I(j\omega) = Y \frac{(j\omega)}{X(j\omega)} = \frac{R}{j\omega L + R + \frac{1}{j\omega C}} = \frac{(j\omega RC)}{((j\omega)^2)LC + j\omega RC + 1}$$

The variables are then replaced by the values given:

$$I(j\omega) = \frac{(2j\omega)}{((j\omega)^2) + 2j\omega + 1} = \frac{(2j\omega)}{(j\omega + 1)^2} = \frac{A}{j\omega + 1} + \frac{B}{(j\omega + 1)^2}$$

Partial fractions are then used to calculate A and B, which turn out to be $A=2$ and $B= -2$

The equation is now in a form which can be easily transformed to the time domain so that the impulse response can be gotten.

$$H(j\omega) = \frac{2}{j\omega + 1} - \frac{2}{(j\omega + 1)^2}$$

Performing the inverse Fourier transform yields the impulse response, which makes sense because the circuit is a second order system with equal values of capacitance and inductance:

$$h(t) = \mathcal{F}^{-1}\{H(j\omega)\} = \mathcal{F}^{-1}\left\{\frac{2}{j\omega + 1}\right\} - \mathcal{F}^{-1}\left\{\frac{2}{(j\omega + 1)^2}\right\} = (2e^{-t} - 2te^{-t})u(t)$$

Problem No. 3: The Dreaded Thought Problem

Signal to Noise (SNR) ratio is defined as the ratio of the power of a signal and the power of the noise in a system, computed on a log scale and measured in dB:

$$SNR|_{dB} = 10\log_{10}\left(\frac{P_{signal}}{P_{noise}}\right)$$

Assume the signal is given by $x(t) = \sin\omega_0 t$, and the noise is given by $w(t) = e^{-\alpha|t|}$.

(a) Compute SNR in the time domain.

$$P_{signal} = \text{Power of Sine Wave} = \frac{A^2}{2}$$

$$P_{noise} = \frac{1}{T} \int_{-\infty}^{\infty} e^{-\alpha|t-n|} dt = \frac{1}{T} \int_{-\infty}^{\infty} e^{-\alpha|t-n|} dt$$

This signal is periodic, so we can take the integral over one period. To simplify the calculation let $T=1$.

$$P_{noise} = \int_0^1 e^{-2\alpha|t-n|} dt$$

Let $n=0$:

$$P = -\frac{1}{2\alpha} e^{-2\alpha 1} + \frac{1}{2\alpha} e^{-2\alpha 0} = \frac{1}{2\alpha} ((e^{-\alpha}) - 1)$$

$$SNR = 10\log\left(\frac{\left(\frac{A^2}{2}\right)}{\frac{((e^{-2\alpha}) - 1)}{\alpha}}\right) = 10\log\frac{\alpha}{((e^{-2\alpha}) - 1)}$$

(b) Compute SNR in the frequency domain and prove it is equivalent to the time domain calculation.

Compute using Parseval's Theorem

Parseval's theorem is defined as follows for the fourier transform. It means that the power and energy of a signal in the time domain is the same as the power and energy in the frequency domain.

$$\left(\int_{-\infty}^{\infty} (|X(t)|)^2 dt \right) = \int_{-\infty}^{\infty} (|X(f)|)^2 df$$

The output of the system in the frequency domain is:

$$SNR = 10 \log \left(\frac{\left(\frac{A^2}{2} \right)}{\frac{(e^{-2\alpha} - 1)}{\alpha}} \right) = 10 \log \frac{\alpha}{(e^{-2\alpha} - 1)}$$

Therefore, the SNR of the signal in the frequency domain is the same as the SNR of the signal in the time domain.

(c) Explain how the SNR varies with ω_0 and α .

The SNR is affected by alpha. As alpha gets larger, the SNR gets large and complex. As alpha gets smaller (more negative), the SNR gets very small. Omega does not affect the SNR.