

Name:

Problem	Points	Score
1a	10	
1b	10	
1c	10	
2a	10	
2b	10	
2c	10	
2d	10	
3a	10	
3b	10	
3c	10	
Total	100	

Notes:

1. The exam is closed books/closed notes - except for one page of notes.
2. Please show ALL work. Incorrect answers with no supporting explanations or work will be given no partial credit.
3. Please indicate clearly your answer to the problem.

Problem No. 1:

- (a) For the signal $x(t) = e^{-\alpha t} + e^{-\beta t} + \text{sinc}(100t)$ where $|\alpha| < 1$ and $|\beta| < 1$, compute the minimum sample frequency required for perfect reconstruction of the signal when it is converted from an analog signal to a discrete-time signal, and reconverted back to an analog signal.

The minimum sampling frequency is _____ Hz.

- (b) The signal shown below is sampled using a sample frequency of 3 Hz. Plot the spectrum of the sampled signal.

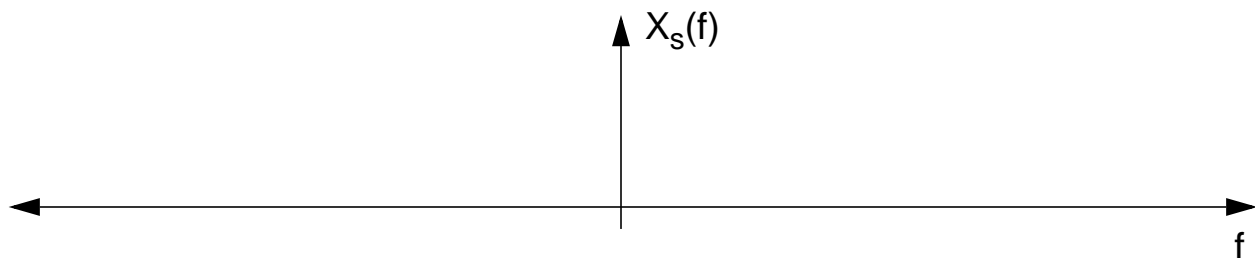
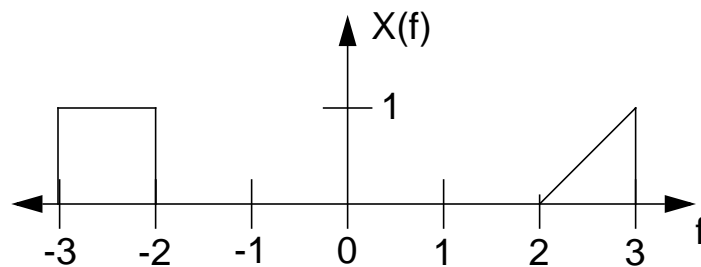

- (c) Can the original signal be reconstructed from the sampled signal with no error? If so, explain how. Explain whether this violates the Sampling Theorem.

If not, explain why the signal cannot be recovered.

Problem No. 2:

(a) Compute the equivalent transfer function for the block diagram below:

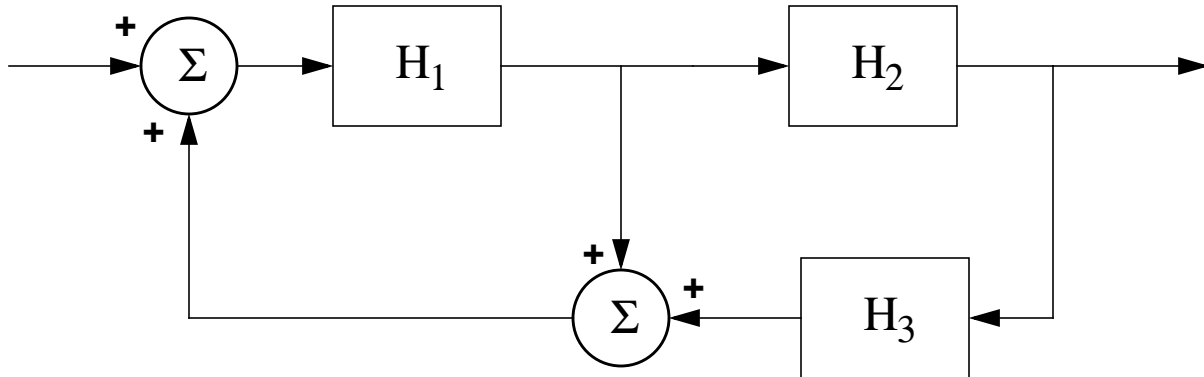

(b) Explain how you would use the Nyquist criterion to determine the stability of this system.

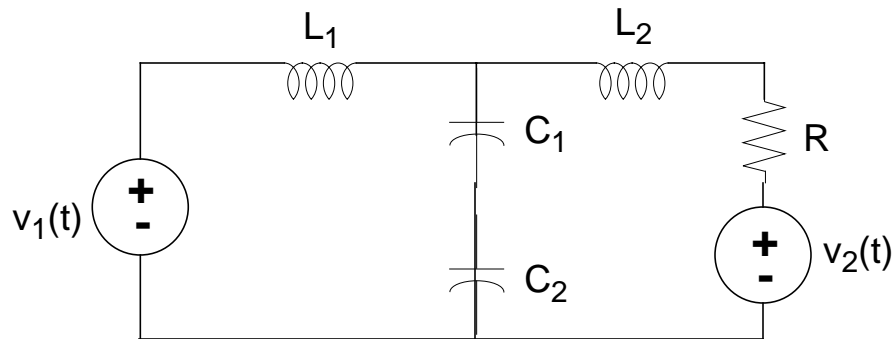

- (c) What is the minimum number of state variables needed to represent the circuit shown above? Explain.
- (d) Derive a state variable representation for this circuit. Note that there are two inputs, $v_1(t)$ and $v_2(t)$. Assume there are two desired outputs, the voltage across the resistor, R , and the current through the resistor.

Problem No. 3:

(a) For the transfer function shown below, sketch the Bode magnitude plot:

$$H(s) = \frac{C(s + \alpha)(s + \lambda)}{(s + \beta)(s + \gamma)}$$

Assume $\beta \ll \alpha \ll \lambda \ll \gamma$, and that $\alpha, \beta, \gamma, \lambda$ are real.

- (b) Describe the transfer function for the system that has the following Bode plot (ignore $\angle X(f)$):

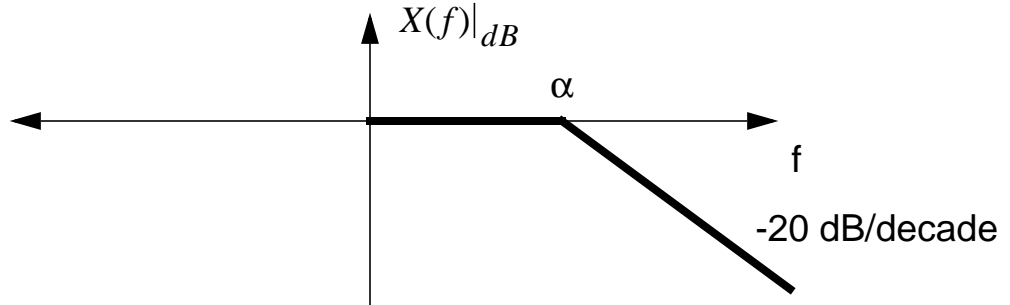

- (c) Describe the transfer function for the system that has the following Bode plot (ignore $\angle X(f)$):

